

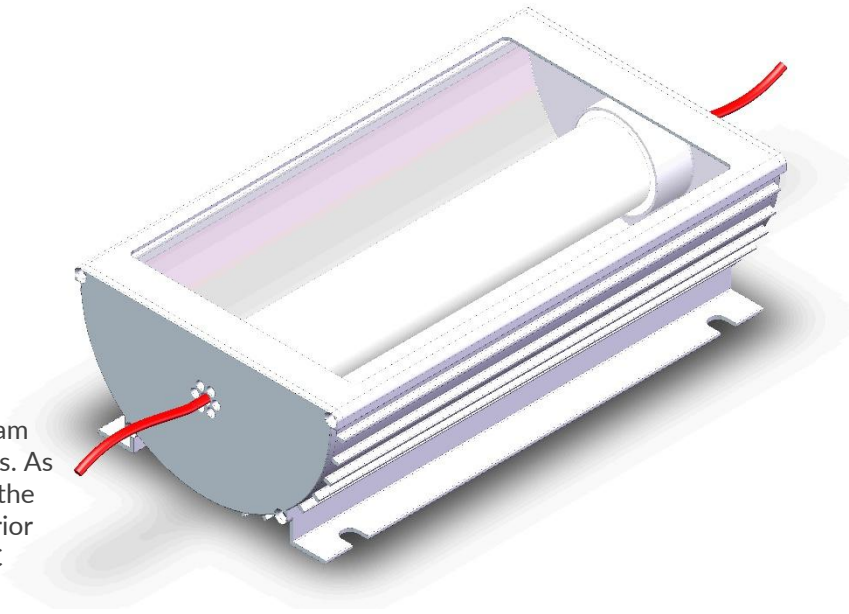

MASTER 100

Unleash the FAR-UVC Power of Invisible Protection

The **MASTER 100** is a premium Far-UVC 100W module, meticulously designed with an aluminum alloy housing, integrated bandpass filter, UV reflector, and a 100 Watts excimer lamp. Engineered to deliver a wide 130-degree beam angle, it ensures extensive coverage for various applications. As a flagship product from the **FIRSTUVC GLOBAL** portfolio, the Master 100 exemplifies cutting-edge technology and superior performance, addressing the evolving demands of Far-UVC technology now and in the future



TECHNICAL DATA

Specification	Details
Dimension	257mm x 150mm x 80mm
Ballast Input Voltage	AC 110V/220V, 50/60Hz
Bulb Power	100 W
Bulb Lifetime	10,000 hours (75%-80% UV output)
UV Intensity ($\mu\text{W}/\text{cm}^2$)	5000 ($\mu\text{W}/\text{cm}^2$)
Beam Angle	130 degrees
Coverage (2m -5m height)	57.8m ² - 361m ²
Material	High purity quartz glass/Aluminum Alloy (Surface Coating)
Operating Temperature	-10°C to +50°C
Model :	FG222-LA100W

PRODUCT INFO

The **MASTER 100** is engineered to provide comprehensive coverage across diverse applications, including livestock farming, healthcare facilities, food processing plants, hotels, and other environments.

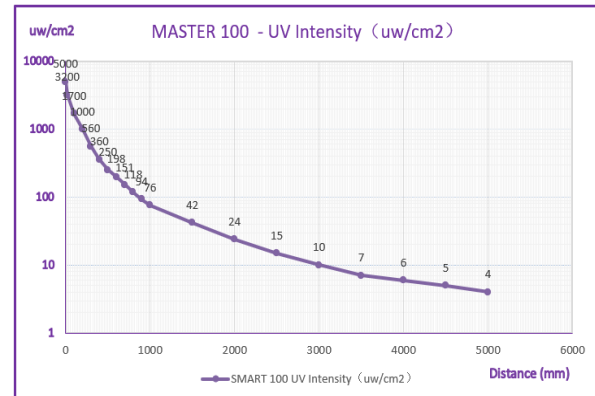

PRODUCT FEATURES

- Utilizes a 100 watts excimer lamp with integrated bandpass filter for precise 222nm wavelength output, ensuring optimal disinfection performance and safety.
- Built with durable aluminum alloy housing for superior heat dissipation, long-term stability, and corrosion resistance.
- Designed with a 130-degree beam angle to deliver extensive irradiation coverage, suitable for large-area sterilization and surface disinfection.
- Equipped with UV reflector to maximize light utilization and ensure efficient UV distribution over targeted surfaces.

CERTIFICATES

The **MASTER 100** is backed by industry-leading certifications and standards, including:

- ISO 9001:2015 Certification for quality.
- FCC/CE/ROHS Compliance for safety.
- Premium-grade components for unmatched performance and durability.
- **MASTER 100** is officially patented

CONTACT

FIRSTUVC GLOBAL LLC
30 N Gould St Ste R
Sheridan, WY 82801 USA

FIRSTUVC GLOBAL LIMITED
Room 2209, 22/F, Nathan Road
Mong Kok, Hong Kong

Phone: +1-307-533-4104 / +86-138-2708-9596
Email: support@firstuvcglobal.com
Website: www.firstuvcglobal.com



MASTER 100

Unleash the FAR-UVC Power of Invisible Protection

Product Diagram

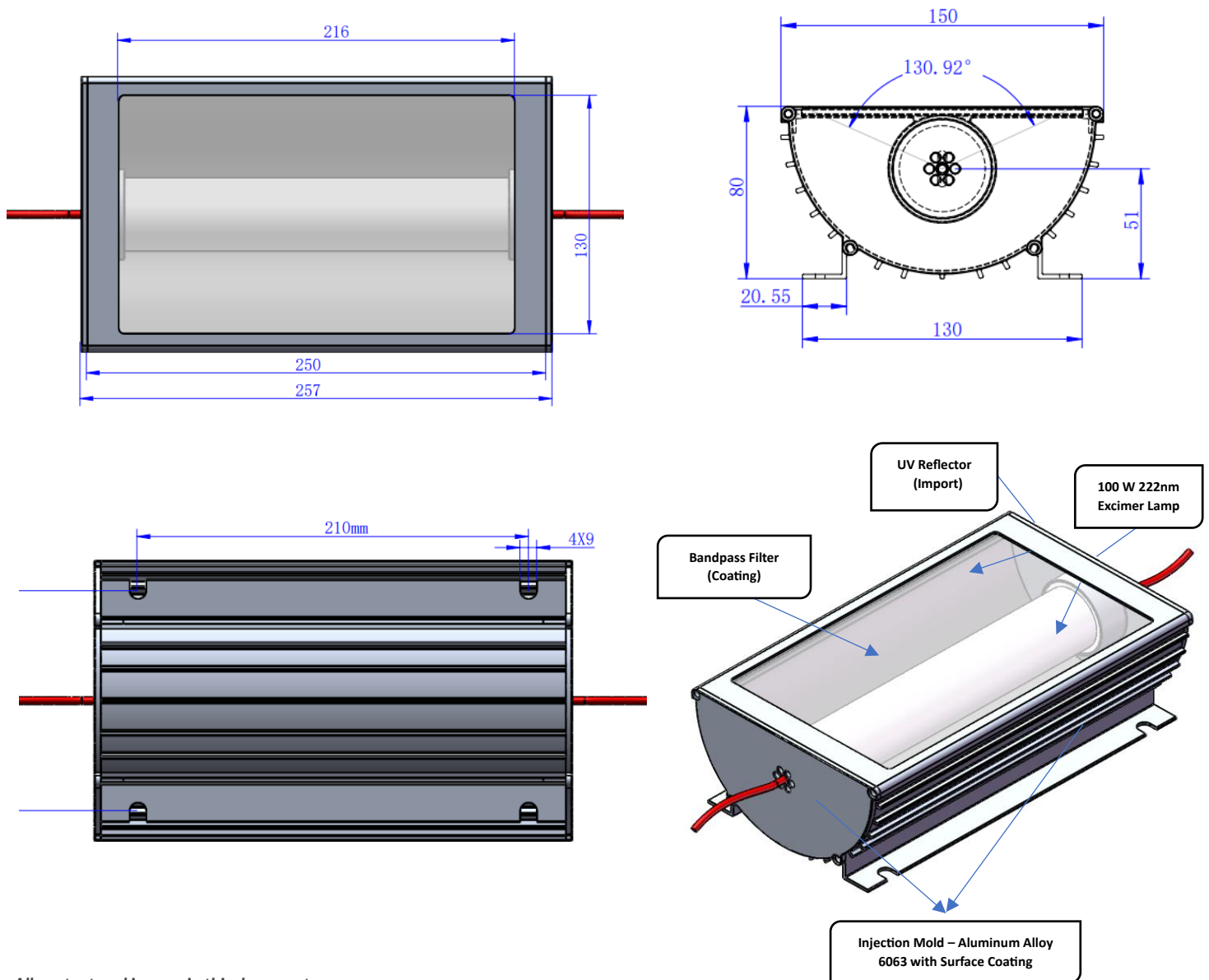

All content and images in this document are protected by copyright law and are the exclusive property of FIRSTUVC GLOBAL LIMITED. Unauthorized copying, sharing, or distribution is strictly prohibited.

CONTACT

FIRSTUVC GLOBAL LLC
30 N Gould St Ste R
Sheridan, WY 82801 USA

FIRSTUVC GLOBAL LIMITED
Room 2209, 22/F, Nathan Road
Mong Kok, Hong Kong

Phone: +1-307-533-4104 / +86-138-2708-9596
Email: support@firstuvcglobal.com
Website: www.firstuvcglobal.com



MASTER 100

Unleash the FAR-UVC Power of Invisible Protection

Power Supply Diagram

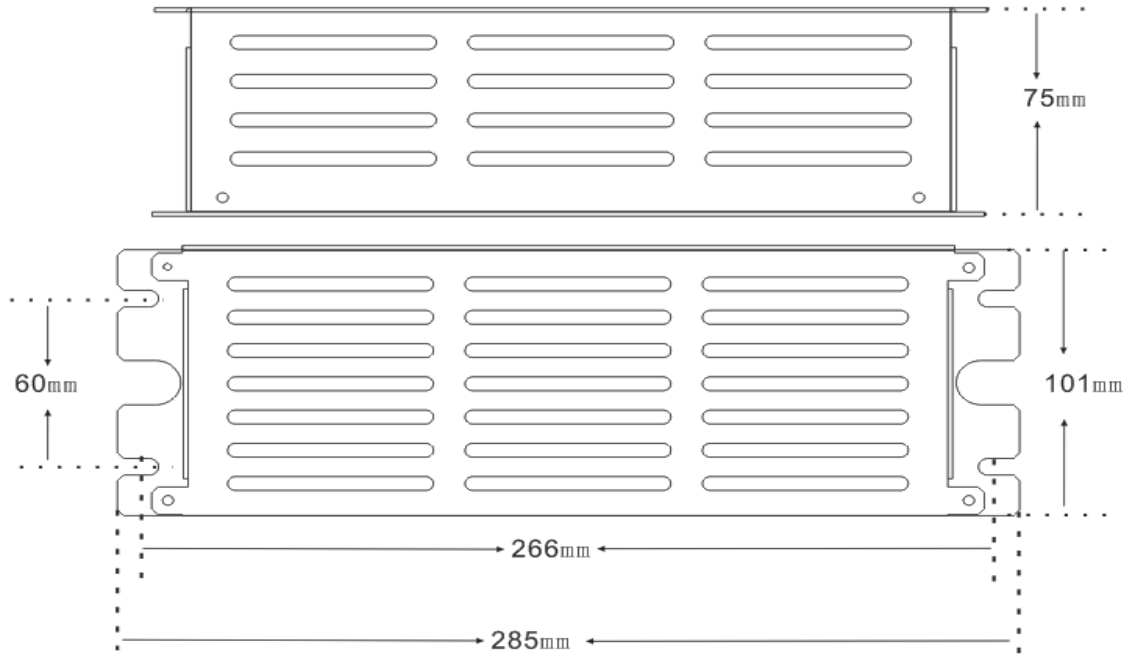

Technical Data

Specification	Details
Power Supply Dimension	L 285mm x W 101mm x H 75mm
Input Voltage	AC 100 - 240V, 50/60Hz
Output Voltage	1 - 5 KV
Output Power	100 W \pm 10%
Power Factor	>0.95PF
Protection	Over-voltage, over-current, open-load, short-circuit, thermal shutdown
Certification	CE/FCC/RoHS
Model	FG222-BA100W

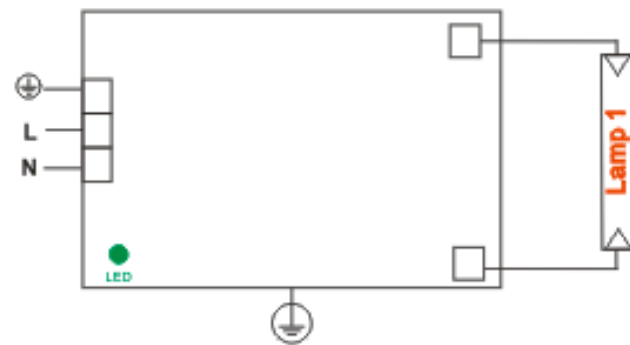

Power Supply Features:

- Inside the circuit board, high-concentration conformal coating is applied for increased protection.
- The enclosure is made of 2mm thick aluminum profile with ample heat dissipation holes around the perimeter.
- The power supply circuit employs a PFC (Power Factor Correction) step-up design.
- The power output remains stable and does not fluctuate with variations in mains voltage.
- Input voltage fluctuations do not affect the power supply's output power.
- The power supply is equipped with a green indicator light to clearly display its operating status.
- The power input terminal uses an integrated connector for easy wiring and a tidy appearance

CONTACT

FIRSTUVC GLOBAL LLC
30 N Gould St Ste R
Sheridan, WY 82801 USA

FIRSTUVC GLOBAL LIMITED
Room 2209, 22/F, Nathan Road
Mong Kok, Hong Kong

Phone: +1-307-533-4104 / +86-138-2708-9596
Email: support@firstuvcglobal.com
Website: www.firstuvcglobal.com



MASTER 100

Unleash the FAR-UVC Power of Invisible Protection

Products Photo

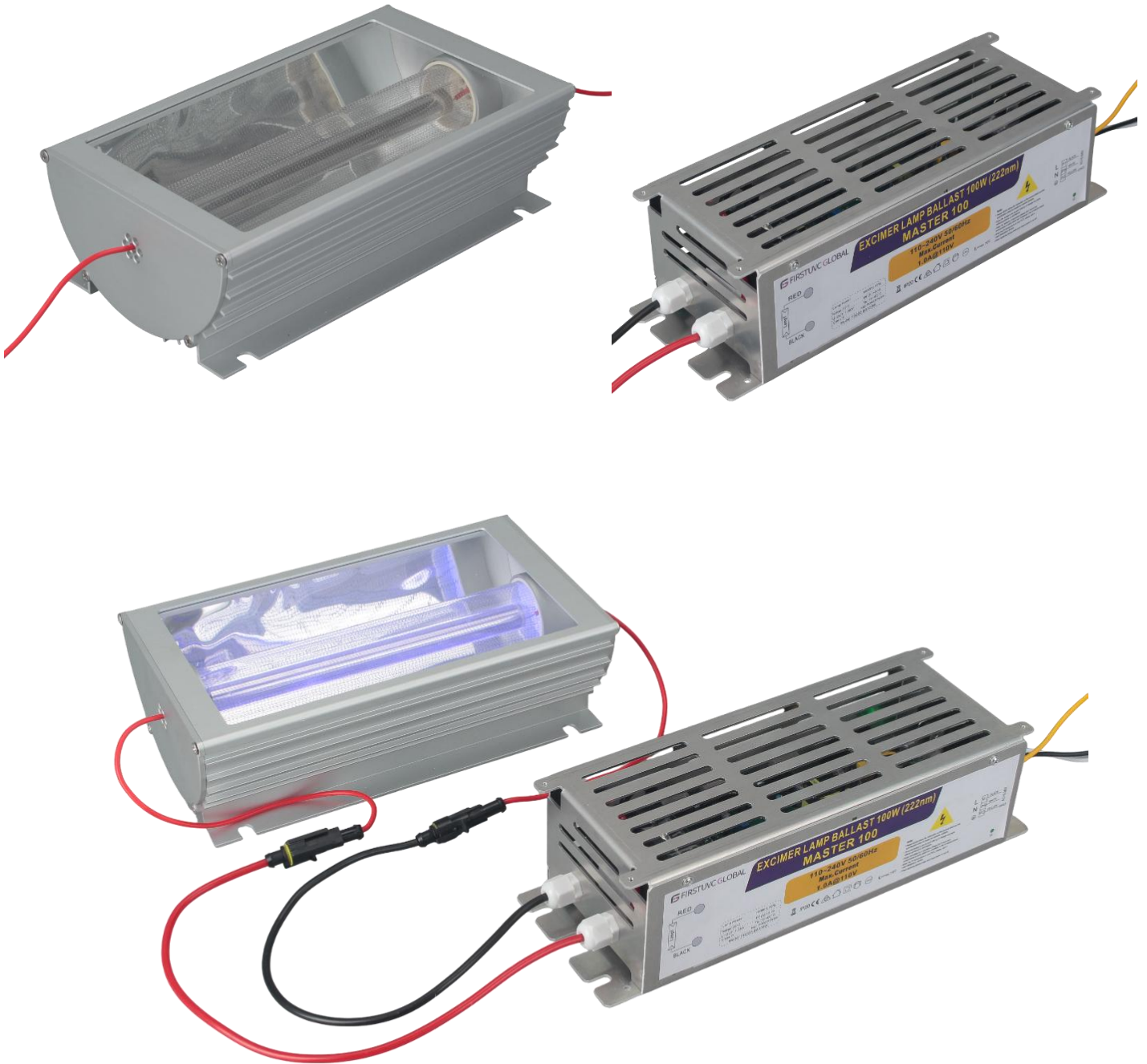

CONTACT

FIRSTUVC GLOBAL LLC
30 N Gould St Ste R
Sheridan, WY 82801 USA

FIRSTUVC GLOBAL LIMITED
Room 2209, 22/F, Nathan Road
Mong Kok, Hong Kong

Phone: +1-307-533-4104 / +86-138-2708-9596

Email: support@firstuvglobal.com

Website: www.firstuvglobal.com